

TECHNICAL SPECIFICATION

Flexair Dimension Detail

| S. No. | Unit Model | Air Volume | Unit Dimension (in mm) | | | | | | | | | | | Cross Sectional Area | Remarks |
|--------|------------|------------|------------------------|------|-----|------|------|------|------|------|------|------|------|----------------------|---------|
| | | CMH | L | L1 | L2 | L3 | L4 | W | H | H1 | H2 | A | B | | |
| 1 | DAHU-1700 | 1700 | 2972 | 685 | 455 | 1135 | 685 | 905 | 1195 | 1120 | 560 | 500 | 300 | 4.0 | |
| 2 | DAHU-3500 | 3500 | 2972 | 685 | 455 | 1135 | 685 | 1035 | 1195 | 1120 | 560 | 700 | 300 | 4.6 | |
| 3 | DAHU-5000 | 5000 | 3272 | 835 | 455 | 1135 | 835 | 1185 | 1575 | 1500 | 750 | 800 | 500 | 7.6 | |
| 4 | DAHU-7000 | 7000 | 3572 | 985 | 455 | 1135 | 985 | 1415 | 1600 | 1500 | 750 | 1000 | 500 | 9.2 | |
| 5 | DAHU-8500 | 8500 | 3572 | 985 | 455 | 1135 | 985 | 1415 | 1820 | 1720 | 860 | 1000 | 600 | 10.8 | |
| 6 | DAHU-10000 | 10000 | 3572 | 985 | 455 | 1135 | 985 | 1630 | 1820 | 1720 | 860 | 1200 | 600 | 12.5 | |
| 7 | DAHU-12000 | 12000 | 4172 | 1285 | 455 | 1135 | 1285 | 1685 | 2190 | 2090 | 1045 | 1200 | 800 | 16.1 | |
| 8 | DAHU-17000 | 17000 | 4172 | 1285 | 455 | 1135 | 1285 | 2005 | 2190 | 2090 | 1045 | 1400 | 800 | 19.4 | |
| 9 | DAHU-20000 | 20000 | 4172 | 1285 | 455 | 1135 | 1285 | 2215 | 2400 | 2300 | 1150 | 1600 | 800 | 23.9 | |
| 10 | DAHU-25000 | 25000 | 4622 | 1460 | 555 | 1135 | 1460 | 2350 | 2930 | 2780 | 1390 | 1600 | 1000 | 28.8 | |
| 11 | DAHU-30000 | 30000 | 5007 | 1585 | 690 | 1135 | 1585 | 2550 | 2930 | 2780 | 1390 | 2200 | 1000 | 31.4 | |
| 12 | DAHU-35000 | 35000 | 5307 | 1735 | 690 | 1135 | 1735 | 2750 | 3510 | 3360 | 1680 | 2200 | 1200 | 42.2 | |
| 13 | DAHU-40000 | 40000 | 5607 | 1885 | 690 | 1135 | 1885 | 2950 | 4230 | 4080 | 2040 | 2400 | 1600 | 56.4 | |
| 14 | DAHU-50000 | 50000 | 5907 | 2035 | 690 | 1135 | 2035 | 3150 | 4230 | 4080 | 2040 | 2400 | 1600 | 60.4 | |
| 15 | DAHU-60000 | 60000 | 6207 | 2185 | 690 | 1135 | 2185 | 3350 | 4550 | 4400 | 2200 | 2600 | 1800 | 70.0 | |

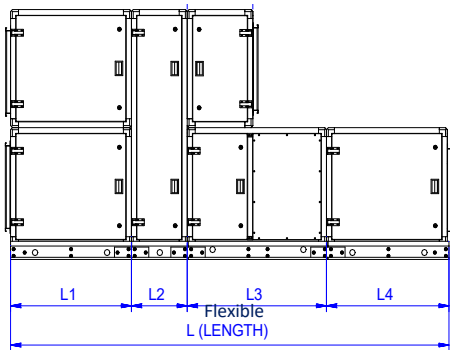

STACKED AHU

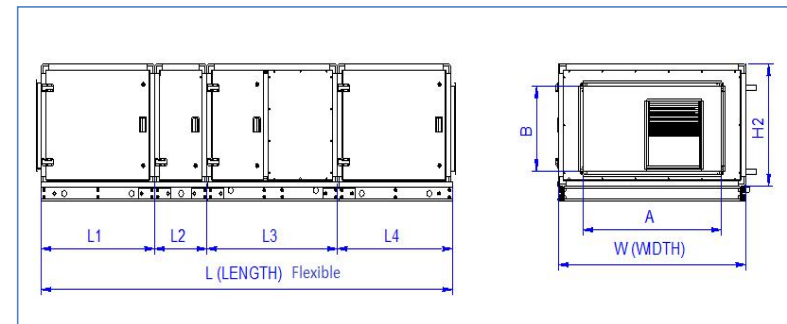
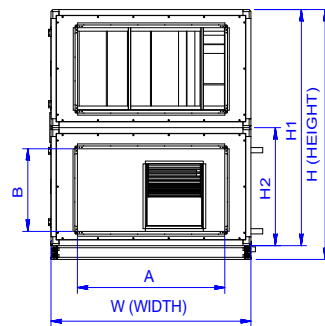

NON STACKED AHU